

(12) INTERNATIONAL APPLICATION PUBLISHED UNDER THE PATENT COOPERATION TREATY (PCT)

(19) World Intellectual Property Organization
International Bureau



(43) International Publication Date
31 October 2002 (31.10.2002)

PCT

(10) International Publication Number
WO 02/086285 A1

- (51) International Patent Classification⁷: E21B 43/10, 23/01
- (21) International Application Number: PCT/GB02/01848
- (22) International Filing Date: 19 April 2002 (19.04.2002)
- (25) Filing Language: English
- (26) Publication Language: English
- (30) Priority Data:
0109711.2 20 April 2001 (20.04.2001) GB
- (71) Applicant (for all designated States except US): E2 TECH LIMITED [GB/GB]; Shell International B.V., P.O. Box 384, NL-2501 CJ The Hague (NL).
- (72) Inventor; and
- (75) Inventor/Applicant (for US only): MACKENZIE, Alan [GB/GB]; 2 Contlaw Placc, Milltimber, Aberdeen AB13 0DS (GB).
- (74) Agent: MURGITROYD & COMPANY; 165-169 Scotland Street, Glasgow G5 8PL (GB).
- (81) Designated States (national): AE, AG, AL, AM, AT, AU, AZ, BA, BB, BG, BR, BY, BZ, CA, CH, CN, CO, CR, CU, CZ, DE, DK, DM, DZ, EE, ES, FI, GB, GD, GE, GH, GM, HR, HU, ID, IL, IN, IS, JP, KE, KG, KP, KR, KZ, LC, LK, LR, LS, LT, LU, LV, MA, MD, MG, MK, MN, MW, MX, MZ, NO, NZ, PL, PT, RO, RU, SD, SE, SG, SI, SK, SL, TJ, TM, TR, TT, TZ, UA, UG, US, UZ, VN, YU, ZA, ZW.
- (84) Designated States (regional): ARIPO patent (GH, GM, KE, LS, MW, MZ, SD, SL, SZ, TZ, UG, ZM, ZW), Eurasian patent (AM, AZ, BY, KG, KZ, MD, RU, TJ, TM), European patent (AT, BE, CH, CY, DE, DK, ES, FI, FR, GB, GR, IE, IT, LU, MC, NL, PT, SE, TR), OAPI patent (BF, BJ, CF, CG, CI, CM, GA, GN, GQ, GW, ML, MR, NE, SN, TD, TG).
- Published:
— with international search report
- For two-letter codes and other abbreviations, refer to the "Guidance Notes on Codes and Abbreviations" appearing at the beginning of each regular issue of the PCT Gazette.



WO 02/086285 A1

(54) Title: APPARATUS AND METHODS FOR RADIALY EXPANDING A TUBULAR MEMBER

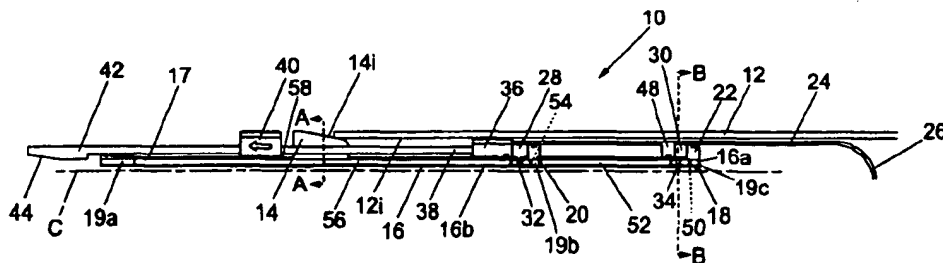

(57) Abstract: Radially expanding a tubular (12) such as a liner or casing, especially in a downward direction. The apparatus includes at least one driver device (20, 22) such as a piston that is typically fluid-actuated, and an expander device (14) is attached to the or each driver device (20, 22). Actuation of the or each driver device (20, 22) causes movement of the expander device (14) to expand the tubular (12). One or more anchoring devices (36, 40), which may be radially offset, are used to substantially prevent the tubular (12) from moving during expansion thereof.

BEST AVAILABLE COPY

1 "Apparatus and Methods for Radially Expanding a
2 Tubular Member"

3

4 The present invention relates to apparatus and
5 methods that are particularly, but not exclusively,
6 suited for radially expanding tubulars in a borehole
7 or wellbore. It will be noted that the term
8 "borehole" will be used herein to refer also to a
9 wellbore.

10

11 It is known to use an expander device to expand at
12 least a portion of a tubular member, such as a
13 liner, casing or the like, to increase the inner and
14 outer diameters of the member. Use of the term
15 "tubular member" herein will be understood as being
16 a reference to any of these and other variants that
17 are capable of being radially expanded by the
18 application of a radial expansion force, typically
19 applied by the expander device, such as an expansion
20 cone.

21

1 The expander device is typically pulled or pushed
2 through the tubular member to impart a radial
3 expansion force thereto in order to increase the
4 inner and outer diameters of the member.
5 Conventional expansion processes are generally
6 referred to as "bottom-up" in that the process
7 begins at a lower end of the tubular member and the
8 cone is pushed or pulled upwards through the member
9 to radially expand it. The terms "upper" and
10 "lower" shall be used herein to refer to the
11 orientation of a tubular member in a conventional
12 borehole, the terms being construed accordingly
13 where the borehole is deviated or a lateral borehole
14 for example. "Lower" generally refers to the end of
15 the member that is nearest the formation or pay
16 zone.
17
18 The conventional bottom-up method has a number of
19 disadvantages, and particularly there are problems
20 if the expander device becomes stuck within the
21 tubular member during the expansion process. The
22 device can become stuck for a number of different
23 reasons, for example due to restrictions or
24 protrusions in the path of the device.
25
26 In addition to this, there are also problems with
27 expanding tubular members that comprise one or more
28 portions of member that are provided with
29 perforations or slots ("perforated"), and one or
30 more portions that are not provided with
31 perforations or slots ("non-perforated"), because
32 the force required to expand a perforated portion is

1 substantially less than that required to expand a
2 non-perforated portion. Thus, it is difficult to
3 expand combinations of perforated and non-perforated
4 tubular members using the same expander device and
5 method.

6
7 Some methods of radial expansion use hydraulic force
8 to propel the cone, where a fluid is pumped into the
9 tubular member down through a conduit such as drill
10 pipe to an area below the cone. The fluid pressure
11 then acts on a lower surface of the cone to provide
12 a propulsion mechanism. It will be appreciated that
13 a portion of the liner to be expanded defines a
14 pressure chamber that facilitates a build up of
15 pressure below the cone to force it upwards and thus
16 the motive power is applied not only to the cone,
17 but also to the tubular member that is to be
18 expanded. It is often the case that the tubular
19 members are typically coupled together using screw
20 threads and the pressure in the chamber can cause
21 the threads between the portions of tubular members
22 to fail. Additionally, the build up of pressure in
23 the pressure chamber can cause structural failure of
24 the member due to the pressure within it if the
25 pressure exceeds the maximum pressure that the
26 material of the member can withstand. If the
27 material of the tubular bursts, or the thread fails,
28 the pressure within the pressure chamber is lost,
29 and it is no longer possible to force the cone
30 through the member using fluid pressure.

31

1 Also, in the case where the cone is propelled
2 through the liner using fluid pressure, where the
3 outer diameter of the tubular member decreases, the
4 surface area of the cone on which the fluid pressure
5 can act is reduced accordingly because the size of
6 the expander device must be in proportion to the
7 size of the tubular member to be expanded.

8
9 According to a first aspect of the present
10 invention, there is provided apparatus for radially
11 expanding a tubular, the apparatus comprising one or
12 more driver devices coupled to an expander device,
13 and one or more anchoring devices engageable with
14 the tubular, wherein the driver device causes
15 movement of the expander device through the tubular
16 to radially expand it whilst the anchoring device
17 prevents movement of the tubular during expansion.

18
19 In this embodiment, the or each anchoring device
20 optionally provides a reaction force to the
21 expansion force generated by the or each driver.

22
23 According to a second aspect of the present
24 invention, there is provided apparatus for radially
25 expanding a tubular, the apparatus comprising one or
26 more driver devices coupled to an expander device,
27 and one or more anchoring devices engageable with
28 the tubular, wherein the or each driver device
29 causes movement of the expander device through the
30 tubular to radially expand it whilst the anchoring
31 device provides a reaction force to the expansion
32 force generated by the or each driver device.

1 In this embodiment, at least one anchoring device
2 optionally prevents movement of the tubular during
3 expansion.

4
5 According to a third aspect of the present
6 invention, there is provided a method of expanding a
7 tubular, the method comprising the step of actuating
8 one or more driver devices to move an expander
9 device within the tubular to radially expand the
10 member.

11
12 The invention also provides apparatus for radially
13 expanding a tubular, the apparatus comprising one
14 ore more driver devices that are coupled to an
15 expander device, where fluid collects in a fluid
16 chamber and acts on the or each driver device to
17 move the expander device.

18
19 The invention further provides a method of radially
20 expanding a tubular, the method comprising the steps
21 of applying pressurised fluid to one ore more driver
22 devices that are coupled to an expander device,
23 where fluid collects in a fluid chamber and acts on
24 the or each driver device to move the expander
25 device.

26
27 This particular embodiment has advantages in that
28 the pressurised fluid acts directly on the or each
29 driver device and not on the tubular itself.

30
31 The or each driver device is typically a fluid-
32 actuated device such as a piston. The piston(s) can

1 be coupled to the expander device by any
2 conventional means. Two or more pistons are
3 typically provided, the pistons typically being
4 coupled in series. Thus, additional expansion force
5 can be provided by including additional pistons.
6 The or each piston is typically formed by providing
7 an annular shoulder on a sleeve. The expander
8 device is typically coupled to the sleeve.

9
10 Optionally, one or more expander devices may be
11 provided. Thus, the tubular can be radially
12 expanded in a step-wise manner. That is, a first
13 expander device radially expands the inner and outer
14 diameters of the member by a certain percentage, a
15 second expander device expands by a further
16 percentage and so on.

17
18 The sleeve is typically provided with ports that
19 allow fluid from a bore of the sleeve to pass into a
20 fluid chamber or piston area on one side of the or
21 each piston. Thus, pressurised fluid can be
22 delivered to the fluid chamber or piston area to
23 move the or each piston.

24
25 The sleeve is typically provided with a ball seat.
26 The ball seat allows the bore of the sleeve to be
27 blocked so that fluid pressure can be applied to the
28 pistons via the ports in the sleeve.

29
30 The fluid chamber or piston area is typically
31 defined between the sleeve and an end member. Thus,
32 pressurised fluid does not act directly on the

1 tubular. This is advantageous as the fluid pressure
2 required for expansion may cause the material of the
3 tubular to stretch or burst. Additionally, the
4 tubular may be a string of tubular members that are
5 threadedly coupled together, and the fluid pressure
6 may be detrimental to the threaded connections.

7
8 The or each anchoring device is typically a one-way
9 anchoring device. The anchoring device(s) can be,
10 for example, a BALLGRAB™ manufactured by BSW
11 Limited. The or each anchoring device is typically
12 actuated by moving at least a portion of it in a
13 first direction. The anchoring device is typically
14 de-actuated by moving said portion in a second
15 direction, typically opposite to the first
16 direction.

17
18 The or each anchoring device typically comprises a
19 plurality of ball bearings that engage in a taper.
20 Movement of the taper in the first direction
21 typically causes the balls to move radially outward
22 to engage the tubular. Movement of the taper in the
23 second direction typically allows the balls to move
24 radially inward and thus disengage the tubular.

25
26 Two anchoring devices are typically provided. One
27 of the anchoring devices is typically laterally
28 offset with respect to the other anchoring device.
29 A first anchoring device typically engages portions
30 of the tubular that are unexpanded, and a second
31 anchoring device typically engages portions of the
32 tubular that have been radially expanded. Thus, at

1 least one anchoring device can be used to grip the
2 tubular and retain it on the apparatus as it is
3 being run into the borehole, and also during
4 expansion of the member.

5
6 The apparatus is typically provided with a fluid
7 path that allows trapped fluid to bypass the
8 apparatus. Thus, fluids trapped at one end of the
9 apparatus can bypass it to the other end of the
10 apparatus.

11
12 The expander device typically comprises an expansion
13 cone. The expansion cone can be of any conventional
14 type and can be made of any conventional material
15 (e.g. steel, steel alloy, tungsten carbide etc).
16 The expander device is typically of a material that
17 is harder than the tubular that it has to expand.
18 It will be appreciated that only the portion(s) of
19 the expander device that contact the tubular need be
20 of the harder material.

21
22 The apparatus typically includes a connector for
23 coupling the apparatus to a string. The connector
24 typically comprises a box connection, but any
25 conventional connector may be used. The string
26 typically comprises a drill string, coiled tubing
27 string, production string, wireline or the like.

28
29 The tubular typically comprises liner, casing, drill
30 pipe etc, but may be any downhole tubular that is of
31 a ductile material and/or is capable of sustaining
32 plastic and/or elastic deformation. The tubular may

1 be a string of tubulars (e.g. a string of individual
2 lengths of liner that have been coupled together).

3

4 The step of moving the piston(s) typically comprises
5 applying fluid pressure thereto.

6

7 The method typically includes the additional step of
8 gripping the tubular during expansion. The step of
9 gripping the tubular typically comprises actuating
10 one or more anchoring devices to grip the tubular.

11

12 The method optionally includes one, some or all of
13 the additional steps of a) reducing the fluid
14 pressure applied to the pistons; b) releasing the or
15 each anchoring device; c) moving the expander device
16 to an unexpanded portion of the tubular; d)
17 actuating the or each anchoring device to grip the
18 tubular; and e) increasing the fluid pressure
19 applied to the pistons to move the expander device
20 to expand the tubular.

21

22 The method optionally includes repeating steps a) to
23 e) above until the entire length of the tubular is
24 expanded.

25

26 Embodiments of the present invention shall now be
27 described, by way of example only, with reference to
28 the accompanying drawings, in which:-

29

30 Fig. 1 is a longitudinal part cross-sectional
31 view of an exemplary embodiment of apparatus
32 for expanding a tubular member;

1 Fig. 2 is a cross-sectional view through the
2 apparatus of Fig. 1 along line A-A in Fig. 1;
3 Fig. 3 is a cross-sectional view through the
4 apparatus of Fig. 1 along line B-B in Fig. 1;
5 and
6 Figs 4 to 7 show a similar view of the
7 apparatus of Fig. 1 in various stages of
8 operation thereof.

9
10 Referring to the drawings, there is shown an
11 exemplary embodiment of apparatus 10 that is
12 particularly suited for radially expanding a tubular
13 member 12 within a borehole (not shown). Fig. 1
14 shows the apparatus 10 in part cross-section and it
15 will be appreciated that the apparatus 10 is
16 symmetrical about the centre line C.

17
18 The tubular member 12 that is to be expanded can be
19 of any conventional type, but it is typically of a
20 ductile material so that it is capable of being
21 plastically and/or elastically expanded by the
22 application of a radial expansion force. Tubular
23 member 12 may comprise any downhole tubular such as
24 drill pipe, liner, casing or the like, and is
25 typically of steel, although other ductile materials
26 may also be used.

27
28 The apparatus 10 includes an expansion cone 14 that
29 may be of any conventional design or type. For
30 example, the cone 14 can be of steel or an alloy of
31 steel, tungsten carbide, ceramic or a combination of
32 these materials. The expansion cone 14 is typically

1 of a material that is harder than the material of
2 the tubular member 12 that it has to expand.
3 However, this is not essential as the cone 14 may be
4 coated or otherwise provided with a harder material
5 at the portions that contact the tubular 12 during
6 expansion.

7
8 The expansion cone 14 is provided with an inclined
9 face 14i that is typically annular and is inclined
10 at an angle of around 20° with respect to the centre
11 line C of the apparatus 10. The inclination of the
12 inclined face 14i can vary from around 5° to 45° but
13 it is found that an angle of around 15° to 25° gives
14 the best performance. This angle provides
15 sufficient expansion without causing the material to
16 rupture and without providing high frictional
17 forces.

18
19 The expansion cone 14 is attached to a first tubular
20 member 16 which in this particular embodiment
21 comprises a portion of coil tubing, although drill
22 pipe etc may be used. A first end 16a of the coil
23 tubing is provided with a ball catcher in the form
24 of a ball seat 18, the purpose of which is to block
25 a bore 16b in the coil tubing 16 through which fluid
26 may pass.

27
28 The coiled tubing 16 is attached to a second tubular
29 member in the form of a sleeve 17 using a number of
30 annular spacers 19a, 19b, 19c. The spacers 19b and
31 19c create a first conduit 52 therebetween, and the
32 spacers 19a, 19b create a second conduit 56

1 therebetween. The spacer 19c is provided with a
2 port 50 and spacer 19b is provided with a port 54,
3 both ports 50, 54 allowing fluid to pass
4 therethrough. The function of the ports 50, 54 and
5 the conduits 52, 56 shall be described below.

6
7 Two laterally-extending annular shoulders are
8 attached to the sleeve 17 and sealingly engage a
9 cylindrical end member 24, the annular shoulders
10 forming first and second pistons 20, 22,
11 respectively. The cylindrical end member 24
12 includes a closed end portion 26 at a first end
13 thereof. The engagement of the first and second
14 pistons 20, 22 with the cylindrical end member 24
15 provides two piston areas 28, 30 in which fluid
16 (e.g. water, brine, drill mud etc) can be pumped
17 into via vents 32, 34 from the bore 16b. The
18 annular shoulders forming the first and second
19 pistons 20, 22 can be sealed to the cylindrical end
20 member 24 using any conventional type of seal (e.g.
21 O-rings, lip-type seals or the like).

22
23 The two piston areas 28, 30 typically have an area
24 of around 15 square inches, although this is
25 generally dependent upon the dimensions of the
26 apparatus 10 and the tubular member 12, and also the
27 expansion force that is required.

28
29 A second end of the cylindrical end member 24 is
30 attached to a first anchoring device 36. The first
31 anchoring device 36 is typically a BALLGRAB™ that is
32 preferably a one-way anchoring device and is

1 supplied by BSW Limited. The BALLGRAB™ works on the
2 principle of a plurality of balls that engage in a
3 taper. Applying a load to the taper in a first
4 direction acts to push the balls radially outwardly
5 and thus they engage an inner surface 12i of the
6 tubular 12 to retain it in position. The gripping
7 motion of the BALLGRAB™ can be released by moving
8 the taper in a second direction, typically opposite
9 to the first direction, so that the balls disengage
10 the inner surface 12i.

11
12 The weight of the tubular member 12 can be carried
13 by the first anchoring device 36 as the apparatus 10
14 is being run into the borehole, but this is not the
15 only function that it performs, as will be
16 described. The first anchoring device 36 is
17 typically a 7 inch (approximately 178mm), 29 pounds
18 per foot type, but the particular size and rating of
19 the device 36 that is used generally depends upon
20 the size, weight and like characteristics of the
21 tubular member 12.

22
23 The first anchoring device 36 is coupled via a
24 plurality of circumferentially spaced-apart rods 38
25 (see Fig. 2 in particular) to a second anchoring
26 device 40 that in turn is coupled to a portion of
27 conveying pipe 42. The second anchoring device 40
28 is typically of the same type as the first anchoring
29 device 36, but could be different as it is not
30 generally required to carry the weight of the member
31 12 as the apparatus 10 is run into the borehole.

32

1 The conveying pipe 42 can be of any conventional
2 type, such as drill pipe, coil tubing or the like.
3 The conveying pipe 42 is provided with a connection
4 44 (e.g. a conventional box connection) so that it
5 can be coupled into a string of, for example drill
6 pipe, coiled tubing etc (not shown). The string is
7 used to convey the apparatus 10 and the tubular
8 member 12.

9
10 The second anchoring device 40 is used to grip the
11 tubular member 12 after it has been radially
12 expanded and is typically located on a longitudinal
13 axis that is laterally spaced-apart from the axis of
14 the first anchoring device 36. This allows the
15 second anchoring device 40 to engage the increased
16 diameter of the member 12 once it has been radially
17 expanded.

18
19 Referring now to Figs 4 to 7, the operation of
20 apparatus 10 shall now be described.

21
22 A ball 46 (typically a $\frac{3}{8}$ inch, approximately 19mm
23 ball) is dropped or pumped down the bore of the
24 string to which the conveying pipe 42 is attached,
25 and thereafter down through the bore 16b of the coil
26 tubing 16 to engage the ball seat 18. The ball 46
27 therefore blocks the bore 16b in the conventional
28 manner. Thereafter, the bore 16b is pressured-up by
29 pumping fluid down through the bore 16b, typically
30 to a pressure of around 5000 psi. The ball seat 18
31 can be provided with a safety-release mechanism
32 (e.g. one or more shear pins) that will allow the

1 pressure within bore 16b to be reduced in the event
2 that the apparatus 10 fails. Any conventional
3 safety-release mechanism can be used.

4
5 The pressurised fluid enters the piston areas 28, 30
6 through the vents 32, 34 respectively and acts on
7 the pistons 20, 22. The fluid pressure at the
8 piston areas 28, 30 causes the coil tubing 16,
9 sleeve 17 and thus the expansion cone 14 to move to
10 the right in Fig. 4 (e.g. downwards when the
11 apparatus 10 is orientated in a conventional
12 borehole) through the tubular member 12 to radially
13 expand the inner and outer diameters thereof, as
14 illustrated in Fig.4.

15
16 During movement of the pistons 20, 22, slight
17 tension is applied to the conveying pipe 42 via the
18 drill pipe or the like to which the apparatus 10 is
19 attached so that the first anchoring device 36 grips
20 the tubular member 12 to retain it in position
21 during the expansion process. Thus, the first
22 anchoring device 36 can be used to grip the tubular
23 member 12 as the apparatus 10 is run into the
24 borehole, and can also used to grip and retain the
25 tubular member 12 in place during at least a part of
26 the expansion process.

27
28 Continued application of fluid pressure through the
29 vents 32, 34 into the piston areas 28, 30 causes the
30 pistons 20, 22 to move to the position shown in Fig.
31 5, where an annular shoulder 48 that extends from
32 the cylindrical end member 24 defines a stop member

1 for movement of the piston 20 (and thus piston 22).
2 Thus, the pistons 20, 22 have extended to their
3 first stroke, as defined by the stop member 48. The
4 length of stroke of the pistons 20, 22 can be
5 anything from around 5ft (approximately 1 and a half
6 metres) to around 30ft (around 6 metres), but this
7 is generally dependant upon the rig handling
8 capability and the length of member 12. The length
9 of the stroke of the pistons 20, 22 can be chosen to
10 suit the particular application and may extend
11 outwith the range quoted.

12

13 Once the pistons 20, 22 have reached their first
14 stroke, the slight upward force applied to the
15 conveying pipe 42 is released so that the first
16 anchoring device 36 disengages the inner surface 12i
17 of the tubular member 12. Thereafter, the conveying
18 pipe 42 and the anchoring device 36, 40 and end
19 member 24 are moved to the right as shown in Fig. 6
20 (e.g. downwards). This can be achieved by lowering
21 the string to which the conveying pipe 42 is
22 attached.

23

24 The second anchoring device 40 is positioned
25 laterally outwardly of the first anchoring device 36
26 so that it can engage the expanded portion 12e of
27 the tubular member 12. Thus, the tubular member 12
28 can be gripped by both the first and second
29 anchoring devices 36, 40, as shown in Fig. 6.

30

31 With the apparatus 10 in the position shown in Fig.
32 6, tension is then applied to the conveying pipe 42

1 so that the first and second anchoring devices 36,
2 40 are actuated to grip the inner surface 12i of the
3 member 12, and fluid pressure (at around 5000 psi)
4 is then applied to the bore 16b to extend the
5 pistons 20, 22. Fluid pressure is continually
6 applied to the pistons 20, 22 via vents 32, 34 to
7 extend them through their next stroke to expand a
8 further portion of the tubular member 12, as shown
9 in Fig. 7.

10

11 This process is then repeated by releasing the
12 tension on the conveying pipe 42 to release the
13 first and second anchoring devices 36, 40, moving
14 them downwards and then placing the conveying pipe
15 42 under tension again to engage the anchoring
16 devices 36, 40 with the member 12. The pressure in
17 the bore 16b is then increased to around 5000 psi to
18 extend the pistons 20, 22 over their next stroke to
19 expand a further portion of the tubular member 12.

20

21 The process described above with reference to Figs 5
22 to 7 is continued until the entire length of the
23 member 12 has been radially expanded. The second
24 anchoring device 40 ensures that the entire length
25 of the member 12 can be expanded by providing a
26 means to grip the member 12. The second anchoring
27 device 40 is typically required as the first
28 anchoring device 36 will eventually pass out of the
29 end of the member 12 and cannot thereafter grip it.
30 However, expansion of the member 12 into contact
31 with the borehole wall (where appropriate) may be
32 sufficient to prevent or restrict movement of the

1 member 12. A friction and/or sealing material (e.g.
2 a rubber) can be applied at axially spaced-apart
3 locations on the outer surface of the member 12 to
4 increase the friction between the member 12 and the
5 wall of the borehole. Further, cement can be
6 circulated through the apparatus 10 prior to the
7 expansion of member 12 (as described below) so that
8 the cement can act as a partial anchor for the
9 member 12 during and/or after expansion.

10

11 Apparatus 10 can be easily pulled out of the
12 borehole once the member 12 has been radially
13 expanded.

14

15 Embodiments of the present invention provide
16 significant advantages over conventional methods of
17 radially expanding a tubular member. In particular,
18 certain embodiments provide a top-down expansion
19 process where the expansion begins at an upper end
20 of the member 12 and continues down through the
21 member. Thus, if the apparatus 10 becomes stuck, it
22 can be easily pulled out of the borehole without
23 having to perform a fishing operation. The
24 unexpanded portions of the tubular 12 are typically
25 below the apparatus 10 and do not prevent retraction
26 of the apparatus 10 from the borehole, unlike
27 conventional bottom-up methods. This is
28 particularly advantageous as the recovery of the
29 stuck apparatus 10 is much simpler and quicker.
30 Furthermore, it is less likely that the apparatus 10
31 cannot be retrieved from the borehole, and thus it
32 is less likely that the borehole will be lost due to

1 a stuck fish. The unexpanded portion can be milled
2 away (e.g. using an over-mill) so that it does not
3 adversely affect the recovery of hydrocarbons, or a
4 new or repaired apparatus can be used to expand the
5 unexpanded portion if appropriate.

6
7 Also, conventional bottom-up methods of radial
8 expansion generally require a pre-expanded portion
9 in the tubular member 12 in which the expander
10 device is located before the expansion process
11 begins. It is not generally possible to fully
12 expand the pre-expanded portion, and in some
13 instances, the pre-expanded portion can restrict the
14 recovery of hydrocarbons as it produces a
15 restriction (i.e. a portion of reduced diameter) in
16 the borehole. However, the entire length of the
17 member 12 can be fully expanded with apparatus 10.

18
19 The purpose of the pre-expanded portion on
20 conventional methods is typically to house the
21 expansion cone as the apparatus is being run into
22 the borehole. In certain embodiments of the
23 invention, an end of the tubular member 12 rests
24 against the expansion cone 14 as it is being run
25 into the borehole, but this is not essential as the
26 first anchoring device 36 can be used to grip the
27 member 12 as apparatus 10 is run in. Thus, a pre-
28 expanded portion is not required.

29
30 The apparatus 10 is a mechanical system that is
31 driven hydraulically, but the material of the
32 tubular member 12 that has to be expanded is not

1 subjected to the expansion pressures during
2 conventional hydraulic expansion, as no fluid acts
3 directly on the tubular member 12 itself, but only
4 on the pistons 20, 22 and the cylindrical end member
5 24. Thus, the expansion force required to expand
6 the tubular member 12 is effectively de-coupled from
7 the force that operates the apparatus 10.

8

9 Also in conventional systems, the movement of the
10 expansion cone 12 is coupled to the drill pipe or
11 the like, in that the drill pipe or the like is
12 typically used to push or pull the expansion cone
13 through the member that is to be expanded. However,
14 with the apparatus 10, the movement of the expansion
15 cone 12 is substantially de-coupled from movement of
16 the drill pipe, at least during movement of the cone
17 14 during expansion. This is because the movement
18 of the pistons 20, 22 by hydraulic pressure causes
19 movement of the expansion cone 14; movement of the
20 drill pipe or the like to which the conveying pipe
21 42 is coupled has no effect on the expansion
22 process, other than to move certain portions of the
23 apparatus 10 within the borehole.

24

25 If higher expansion forces are required, then
26 additional pistons can be added to provide
27 additional force to move the expansion cone 14 and
28 thus provide additional expansion forces. The
29 additional pistons can be added in series to provide
30 additional expansion force. Thus, there is no
31 restriction on the amount of expansion force that
32 can be applied as further pistons can be added; the

1 only restriction would be the overall length of the
2 apparatus 10. This is particularly useful where the
3 liner, casing and cladding are made of chrome as
4 this generally requires higher expansion forces.
5 Also, the connectors between successive portions of
6 liner and casing etc that are of chrome are
7 critical, and as this material is typically very
8 hard, it requires higher expansion forces.

9
10 The apparatus 10 can be used to expand small sizes
11 of tubular member 12 (API grades) up to fairly large
12 diameter members, and can also be used with
13 lightweight pipe with a relatively small wall
14 thickness (of less than 5mm) and on tubulars having
15 a relatively large wall thicknesses.

16
17 Furthermore, the hydraulic fluid that is used to
18 move the pistons 20, 22 can be recycled and is thus
19 not lost into the formation. Conventional expansion
20 methods using hydraulic or other motive powers can
21 cause problems with "squeeze" where fluids in the
22 borehole that are used to propel the expander
23 device, force fluids in the borehole below the
24 device back into the formation, which can cause
25 damage to the formation and prevent it from
26 producing hydrocarbons.

27
28 However, the hydraulic fluid that is used to drive
29 the pistons 20, 22 is retained within the apparatus
30 10 by the ball 46, and thus will not adversely
31 effect the formation or pay zone.

32

1 In addition to this, apparatus 10 is provided with a
2 path through which fluid that may be trapped below
3 the apparatus 10 (that is fluid that is to the right
4 of the apparatus 10 in Fig. 1) can flow through the
5 apparatus 10 to the annulus above it (to the left in
6 Fig. 1).

7

8 Referring to Figs 1 and 3 in particular, this is
9 achieved by providing one or more circumferentially
10 spaced apart ports 50 that allow fluid to travel
11 through the spacer 19c and into the annular conduit
12 52, through the ports 54 in the spacer 19b into the
13 second conduit 56, and then out into the annulus
14 through a vent 58. Thus, fluid from below the
15 apparatus 10 can be vented to above the apparatus
16 10, thereby reducing the possibility of damage to
17 the formation or pay zone, and also substantially
18 preventing the movement of the apparatus 10 from
19 being arrested due to trapped fluids.

20

21 Additionally, the apparatus 10 can be used to
22 circulate fluids before the ball 46 is dropped into
23 the ball seat 18, and thus cement or other fluids
24 can be circulated before the tubular member 12 is
25 expanded. This is particularly advantageous as
26 cement could be circulated into the annulus between
27 the member 12 and the liner or open borehole that
28 the member 12 is to engage, to secure the member 12
29 in place.

30

31 It will also be appreciated that a number of
32 expansion cones 14 can be provided in series so that

1 there is a step-wise expansion of the member 12.
2 This is particularly useful where the member 12 is
3 to be expanded to a significant extent, and the
4 force required to expand it to this extent is
5 significant and cannot be produced by a single
6 expansion cone. Although the required force may be
7 achieved by providing additional pistons (e.g. three
8 or more), there may be a restriction in the overall
9 length of the apparatus 10 that precludes this.

10

11 The apparatus 10 can be used to expand portions of
12 tubular that are perforated and portions that are
13 non-perforated. This is because the pressure
14 applied to the pistons 20, 22 can be increased or
15 decreased to provide for a higher or lower expansion
16 force. Thus, apparatus 10 can be used to expand
17 sand screens and strings of tubulars that include
18 perforated and non-perforated portions.

19

20 Embodiments of the present invention provide
21 advantages over conventional methods and apparatus
22 in that the apparatus can be used with small sizes
23 of tubulars. The force required to expand small
24 tubulars can be high, and this high force cannot
25 always be provided by conventional methods because
26 the size of the tubular reduces the amount of force
27 that can be applied, particularly where the cone is
28 being moved by hydraulic pressure. However,
29 embodiments of the present invention can overcome
30 this because the expansion force can be increased by
31 providing additional pistons.

32

1 Modifications and improvements may be made to the
2 foregoing without departing from the scope of the
3 present invention. For example, it will be
4 appreciated that the term "borehole" can refer to
5 any hole that is drilled to facilitate the recovery
6 of hydrocarbons, water or the like.
7

1 CLAIMS

2

3 1. Apparatus for radially expanding a tubular
4 comprising one or more driver devices (20, 22)
5 coupled to an expander device (14), and one or more
6 anchoring devices (36, 40) engageable with the
7 tubular (12), wherein the driver device (20, 22)
8 causes movement of the expander device (14) through
9 the tubular (12) to radially expand it whilst the
10 anchoring device (36, 40) prevents movement of the
11 tubular (12) during expansion.

12

13 2. Apparatus according to claim 1, wherein the or
14 each anchoring device (36, 40) provides a reaction
15 force to the expansion force generated by the or
16 each driver device (20, 22).

17

18 3. Apparatus according to either preceding claim,
19 wherein the or each driver device (20, 22) is a
20 fluid-actuated device.

21

22 4. Apparatus according to any preceding claim,
23 wherein the or each driver device comprises a piston
24 (20, 22).

25

26 5. Apparatus according to claim 4, wherein two or
27 more pistons (20, 22) are provided, the pistons (20,
28 22) being coupled in series.

29

30 6. Apparatus according to claim 4 or claim 5,
31 wherein the or each piston (20, 22) is formed by
32 providing an annular shoulder on a sleeve (16, 17).

1 7. Apparatus according to claim 6, wherein the
2 expander device (14) is coupled to the sleeve (16,
3 17).

4
5 8. Apparatus according to claim 6 or claim 7,
6 wherein the sleeve (16, 17) is provided with ports
7 (32, 34) that allow fluid from a bore (16b) of the
8 sleeve (16, 17) to pass into a fluid chamber (28,
9 30) or piston area (28, 30) on one side of the or
10 each piston (20, 22).

11
12 9. Apparatus according to claim 8, wherein the
13 sleeve (16, 17) is provided with a ball seat (18).

14
15 10. Apparatus according to claim 8 or claim 9,
16 wherein the fluid chamber (28, 30) or piston area
17 (28, 30) is defined between the sleeve (16, 17) and
18 an end member (24, 26).

19
20 11. Apparatus according to any preceding claim,
21 wherein two or more expander devices (14) are
22 provided.

23
24 12. Apparatus according to any preceding claim,
25 wherein the or each anchoring device (36, 40) is a
26 one-way anchoring device.

27
28 13. Apparatus according to any preceding claim,
29 wherein the or each anchoring device (36, 40) is
30 actuated by moving at least a portion of it in a
31 first direction.

32

1 14. Apparatus according to claim 13, wherein the or
2 each anchoring device (36, 40) is de-actuated by
3 moving said portion in a second direction.

4

5 15. Apparatus according to any preceding claim,
6 wherein a first anchoring device (36) is laterally
7 offset with respect to a second anchoring device
8 (40).

9

10 16. Apparatus for radially expanding a tubular
11 comprising one or more driver devices (20, 22)
12 coupled to an expander device (14), and one or more
13 anchoring devices (36, 40) engageable with the
14 tubular (12), wherein the or each driver device (20,
15 22) causes movement of the expander device (14)
16 through the tubular (12) to radially expand it
17 whilst the anchoring device (36, 40) provides a
18 reaction force to the expansion force generated by
19 the or each driver device (20, 22).

20

21 17. Apparatus according to claim 16, wherein at
22 least one anchoring device (36, 40) prevents
23 movement of the tubular (12) during expansion.

24

25 18. Apparatus according to claim 16 or claim 17,
26 wherein the or each driver device (20, 22) is a
27 fluid-actuated device.

28

29 19. Apparatus according to any one of claims 16 to
30 18, wherein the or each driver device comprises a
31 piston (20, 22).

32

1 20. Apparatus according to claim 19, wherein two or
2 more pistons (20, 22) are provided, the pistons (20,
3 22) being coupled in series.

4

5 21. Apparatus according to claim 19 or claim 20,
6 wherein the or each piston (20, 22) is formed by
7 providing an annular shoulder on a sleeve (16, 17).

8

9 22. Apparatus according to claim 21, wherein the
10 expander device (14) is coupled to the sleeve (16,
11 17).

12

13 23. Apparatus according to claim 21 or claim 22,
14 wherein the sleeve (16, 17) is provided with ports
15 (32, 34) that allow fluid from a bore (16b) of the
16 sleeve (16, 17) to pass into a fluid chamber (28,
17 30) or piston area (28, 30) on one side of the or
18 each piston (20, 22).

19

20 24. Apparatus according to claim 23, wherein the
21 sleeve (16, 17) is provided with a ball seat (18).

22

23 25. Apparatus according to claim 23 or claim 24,
24 wherein the fluid chamber (28, 30) or piston area
25 (28, 30) is defined between the sleeve (16, 17) and
26 an end member (24, 26).

27

28 26. Apparatus according to any one of claims 16 to
29 25, wherein two or more expander devices (14) are
30 provided.

31

- 1 27. Apparatus according to any one of claims 16 to
2 26, wherein the or each anchoring device (36, 40) is
3 a one-way anchoring device.
4
- 5 28. Apparatus according to any one of claims 16 to
6 27, wherein the or each anchoring device (36, 40) is
7 actuated by moving at least a portion of it in a
8 first direction.
9
- 10 29. Apparatus according to claim 28, wherein the or
11 each anchoring device (36, 40) is de-actuated by
12 moving said portion in a second direction.
13
- 14 30. Apparatus according to any one of claims 16 to
15 29, wherein a first anchoring device (36) is
16 laterally offset with respect to a second anchoring
17 device (40).
18
- 19 31. Apparatus for radially expanding a tubular
20 comprising one or more driver devices (20, 22) that
21 are coupled to an expander device (14), where fluid
22 collects in a fluid chamber (28, 30) and acts on the
23 or each driver device (20, 22) to move the expander
24 device (14).
25
- 26 32. Apparatus according to claim 31, wherein the or
27 each driver device comprises a piston (20, 22).
28
- 29 33. Apparatus according to 32, wherein two or more
30 pistons (20, 22) are provided, the pistons (20, 22)
31 being coupled in series.
32

- 1 34. Apparatus according to claim 32 or claim 33,
2 wherein the or each piston (20, 22) is formed by
3 providing an annular shoulder on a sleeve (16, 17).
4
- 5 35. Apparatus according to claim 34, wherein the
6 expander device (14) is coupled to the sleeve (16,
7 17).
8
- 9 36. Apparatus according to claim 34 or claim 35,
10 wherein the or each fluid chamber (28, 30) is formed
11 on one side of the or each piston (20, 22) between
12 the sleeve (16, 17) and an end member (24, 26).
13
- 14 37. Apparatus according to claim 36, wherein the
15 sleeve (16, 17) is provided with ports (32, 34) that
16 allow fluid from a bore (16b) of the sleeve (16, 17)
17 to pass into the or each fluid chamber (28, 30).
18
- 19 38. Apparatus according to claim 37, wherein the
20 sleeve (16, 17) is provided with a ball seat (18).
21
- 22 39. Apparatus according to any one of claims 31 to
23 38, wherein two or more expander devices (14) are
24 provided.
25
- 26 40. Apparatus according to any one of claims 31 to
27 39, wherein the apparatus includes one or more
28 anchoring devices (36, 40) that can engage the
29 tubular (12) to prevent movement of the tubular (12)
30 during expansion.
31

1 41. Apparatus according to claim 40, wherein the or
2 each anchoring device (36, 40) is actuated by moving
3 at least a portion of it in a first direction.

4

5 42. Apparatus according to claim 41, wherein the or
6 each anchoring device (36, 40) is de-actuated by
7 moving said portion in a second direction.

8

9 43. Apparatus according to any one of claims 40 to
10 42, wherein a first anchoring device (36) is
11 laterally offset with respect to a second anchoring
12 device (40).

13

14 44. A method of expanding a tubular, the method
15 comprising the step of actuating one or more driver
16 devices (20, 22) to move an expander device (14)
17 within the tubular (12) to radially expand the
18 tubular (12).

19

20 45. A method according to claim 44, wherein the
21 step of actuating the or each driver device (20, 22)
22 comprises applying fluid pressure thereto.

23

24 46. A method according to claim 44 or claim 45,
25 wherein the method includes the additional step of
26 gripping the tubular (12) during expansion.

27

28 47. A method according to claim 46, wherein the
29 step of gripping the tubular (12) comprises
30 actuating one or more anchoring devices (36, 40) to
31 grip the tubular (12).

32

1 48. A method according to claim 47, the method
2 including one, some or all of the additional steps
3 of a) reducing the fluid pressure applied to the or
4 each driver device (20, 22); b) releasing the or
5 each anchoring device (36, 40); c) moving the
6 expander device (14) to an unexpanded portion of the
7 tubular (12); d) actuating the or each anchoring
8 device (36, 40) to grip the tubular (12); and e)
9 increasing the fluid pressure applied to the or each
10 driver device (20, 22) to move the expander device
11 (14) to expand the tubular (12).
12

13 49. A method according to claim 48, wherein the
14 method includes repeating steps a) to e) until the
15 entire length of the tubular (12) is expanded.
16

17 50. A method of radially expanding a tubular
18 comprising the steps of applying pressurised fluid
19 to one or more driver devices (20, 22) that are
20 coupled to an expander device (14), where fluid
21 collects in a fluid chamber (28, 30) and acts on the
22 or each driver device (20, 22) to move the expander
23 device (14).
24

25 51. A method according to claim 50, wherein the
26 method includes the additional step of gripping the
27 tubular (12) during expansion.
28

29 52. A method according to claim 51, wherein the
30 step of gripping the tubular (12) comprises
31 actuating one or more anchoring devices (36, 40) to
32 grip the tubular (12).

1 53. A method according to claim 52, the method
2 including one, some or all of the additional steps
3 of a) reducing the fluid pressure applied to the or
4 each driver device (20, 22); b) releasing the or
5 each anchoring device (36, 40); c) moving the
6 expander device (14) to an unexpanded portion of the
7 tubular (12); d) actuating the or each anchoring
8 device (36, 40) to grip the tubular (12); and e)
9 increasing the fluid pressure applied to the or each
10 driver device (20, 22) to move the expander device
11 (14) to expand the tubular.

12

13 54. A method according to claim 53, wherein the
14 method includes repeating steps a) to e) until the
15 entire length of the tubular (12) is expanded.

16

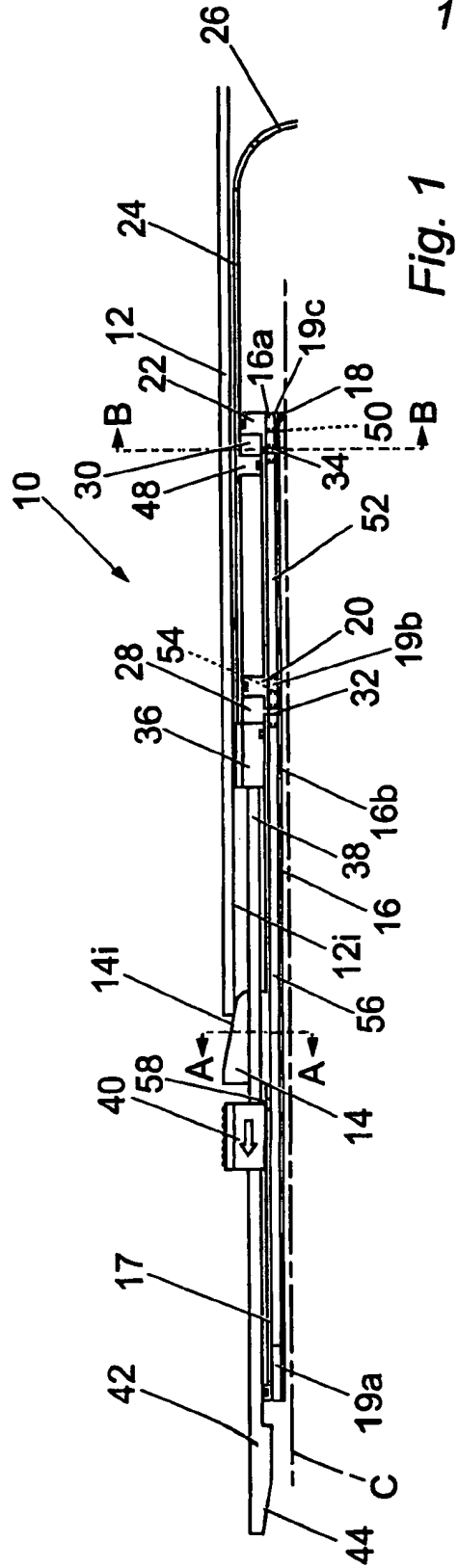
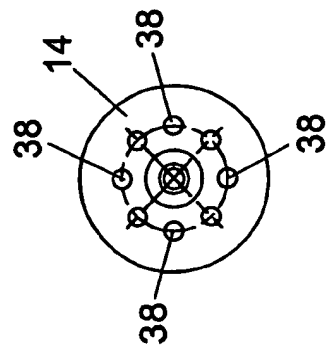
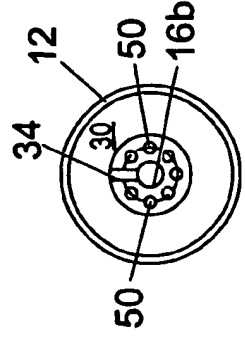

Fig. 1



Section A-A



Section B-B

Fig. 2

Fig. 3

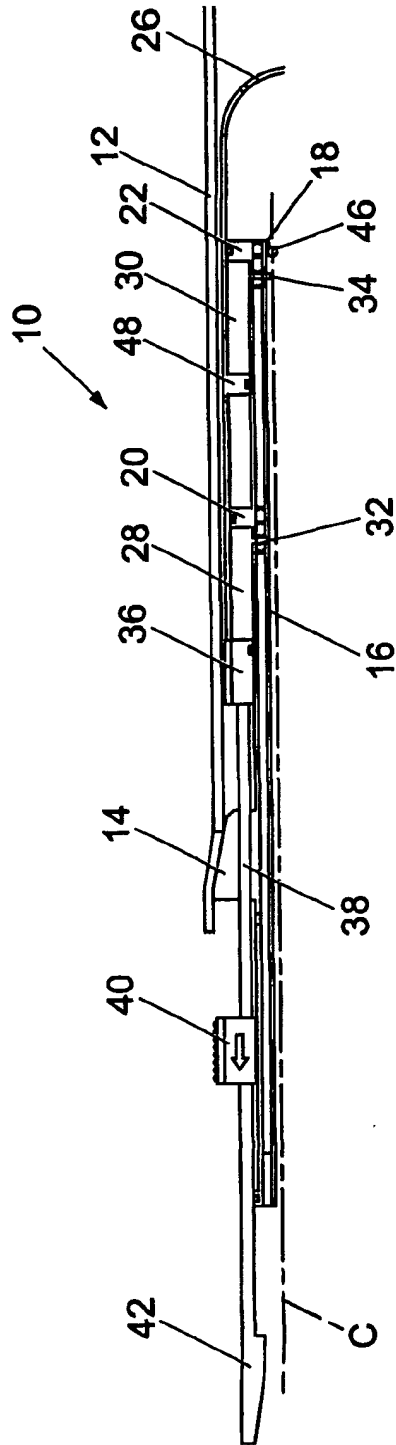

Fig. 4

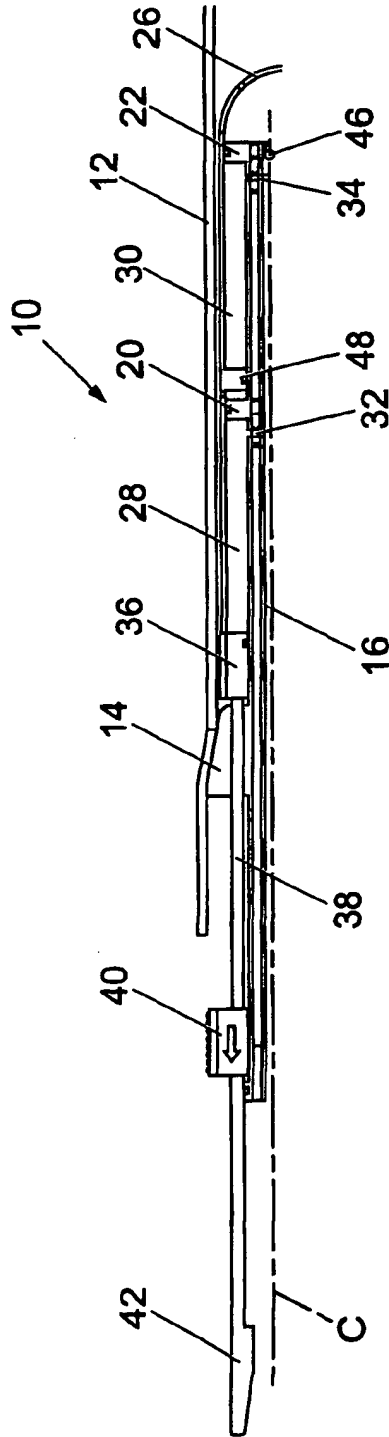

Fig. 5

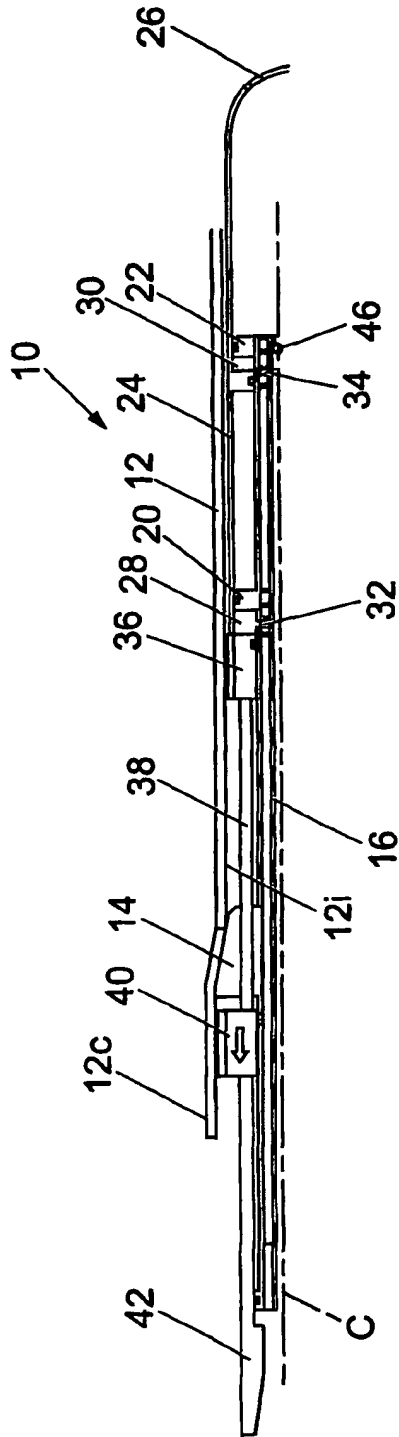

Fig. 6

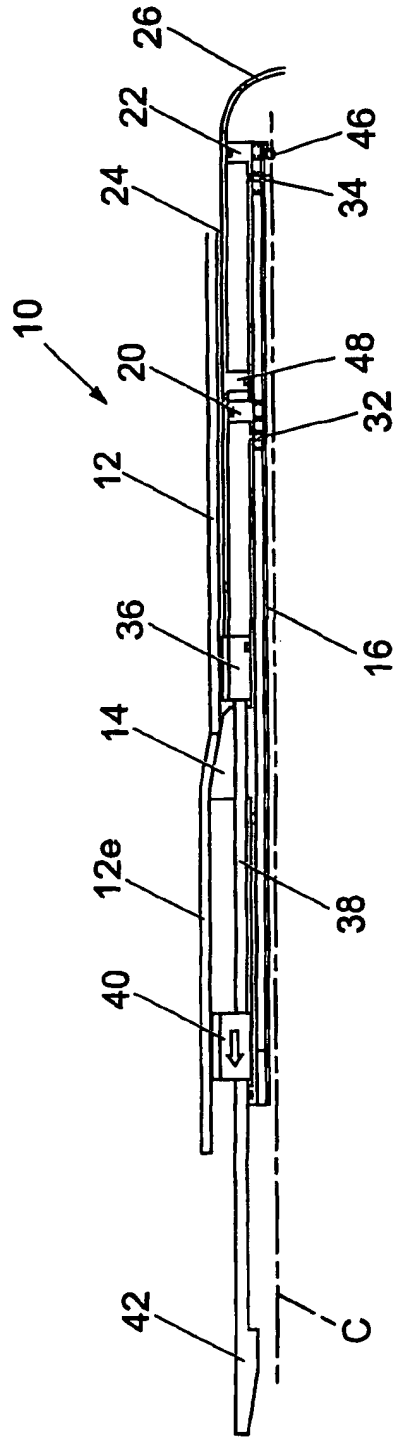

Fig. 7

INTERNATIONAL SEARCH REPORT

International Application No
PCT/GB 02/01848

A. CLASSIFICATION OF SUBJECT MATTER IPC 7 E21B43/10 E21B23/01		
According to International Patent Classification (IPC) or to both national classification and IPC		
B. FIELDS SEARCHED		
Minimum documentation searched (classification system followed by classification symbols) IPC 7 E21B		
Documentation searched other than minimum documentation to the extent that such documents are included in the fields searched		
Electronic data base consulted during the International search (name of data base and, where practical, search terms used) EPO-Internal		
C. DOCUMENTS CONSIDERED TO BE RELEVANT		
Category*	Citation of document, with indication, where appropriate, of the relevant passages	Relevant to claim No.
X	US 3 203 451 A (VINCENT RENIC P) 31 August 1965 (1965-08-31)	1-8,10, 11,13, 14, 16-23, 25,26, 28,29, 31-37, 39-42, 44-54
Y	column 2, line 47-50; figures 1-3,6,13 column 7, line 64 -column 8, line 35	9,12,15, 24,27, 30,38,43
Y	US 3 746 092 A (LAND K) 17 July 1973 (1973-07-17) figure 3	9,24,38
	-/-	
<input checked="" type="checkbox"/> Further documents are listed in the continuation of box C.		
<input checked="" type="checkbox"/> Patent family members are listed in annex.		
* Special categories of cited documents :		
A document defining the general state of the art which is not considered to be of particular relevance *E* earlier document but published on or after the international filing date *L* document which may throw doubts on priority claim(s) or which is cited to establish the publication date of another citation or other special reason (as specified) *O* document referring to an oral disclosure, use, exhibition or other means *P* document published prior to the international filing date but later than the priority date claimed *T* later document published after the international filing date or priority date and not in conflict with the application but cited to understand the principle or theory underlying the invention *X* document of particular relevance; the claimed invention cannot be considered novel or cannot be considered to involve an inventive step when the document is taken alone *Y* document of particular relevance; the claimed invention cannot be considered to involve an inventive step when the document is combined with one or more other such documents, such combination being obvious to a person skilled in the art. *A* document member of the same patent family		
Date of the actual completion of the international search 8 August 2002		Date of mailing of the international search report 16/08/2002
Name and mailing address of the ISA European Patent Office, P.B. 5618 Patentlaan 2 NL - 2280 HV Rijswijk Tel. (+31-70) 340-2040, Tx. 31 651 epo nl, Fax (+31-70) 340-3018		Authorized officer van Berlo, A

INTERNATIONAL SEARCH REPORT

International Application No
PCT/GB 02/01848

C.(Continuation) DOCUMENTS CONSIDERED TO BE RELEVANT		
Category *	Citation of document, with indication, where appropriate, of the relevant passages	Relevant to claim No.
Y	US 4 712 615 A (DOCKINS JR ROY R ET AL) 15 December 1987 (1987-12-15) figures 12,27	12,27
Y	WO 01 18355 A (DUCASSE CHRISTOPHER ;E2TECH LTD (GB); OOSTERLING PETER (NL)) 15 March 2001 (2001-03-15) page 10, line 23 -page 11, line 26; figure 1	15,30,43
P,X	WO 01 98623 A (COOK ROBERT LANCE ;HAUT RICHARD CARL (US); ZWALD EDWIN ARNOLD JR () 27 December 2001 (2001-12-27) the whole document	1-4, 12-14, 16-19, 27-29, 31,32, 40-42, 44-48, 50-53
X	US 3 203 483 A (VINCENT RENIC P) 31 August 1965 (1965-08-31) the whole document	1
A	US 5 785 120 A (SMALLEY MICHAEL T ET AL) 28 July 1998 (1998-07-28) figure 1D	1,16,31, 44,50
A	US 6 142 230 A (WRIGHT RALPH D ET AL) 7 November 2000 (2000-11-07) column 15, line 59 -column 16, line 28	1

INTERNATIONAL SEARCH REPORT

Information on patent family members

International Application No
PCT/GB 02/01848

Patent document cited in search report		Publication date	Patent family member(s)	Publication date
US 3203451	A	31-08-1965	US 3179168 A US 3203483 A	20-04-1965 31-08-1965
US 3746092	A	17-07-1973	NONE	
US 4712615	A	15-12-1987	NONE	
WO 0118355	A	15-03-2001	AU 7021100 A EP 1210503 A1 WO 0118355 A1 NO 20021082 A	10-04-2001 05-06-2002 15-03-2001 13-03-2002
WO 0198623	A	27-12-2001	AU 6981001 A WO 0198623 A1	02-01-2002 27-12-2001
US 3203483	A	31-08-1965	US 3179168 A US 3203451 A	20-04-1965 31-08-1965
US 5785120	A	28-07-1998	AU 732007 B2 AU 4955097 A EP 0948703 A2 WO 9821444 A2 NO 991666 A NO 20021323 A US 6142230 A US 5957195 A	12-04-2001 03-06-1998 13-10-1999 22-05-1998 23-06-1999 23-06-1999 07-11-2000 28-09-1999
US 6142230	A	07-11-2000	US 5957195 A US 5785120 A AU 1054400 A EP 1127210 A1 WO 0026502 A1 NO 20011854 A AU 732007 B2 AU 4955097 A EP 0948703 A2 WO 9821444 A2 NO 991666 A NO 20021323 A	28-09-1999 28-07-1998 22-05-2000 29-08-2001 11-05-2000 12-06-2001 12-04-2001 03-06-1998 13-10-1999 22-05-1998 23-06-1999 23-06-1999